

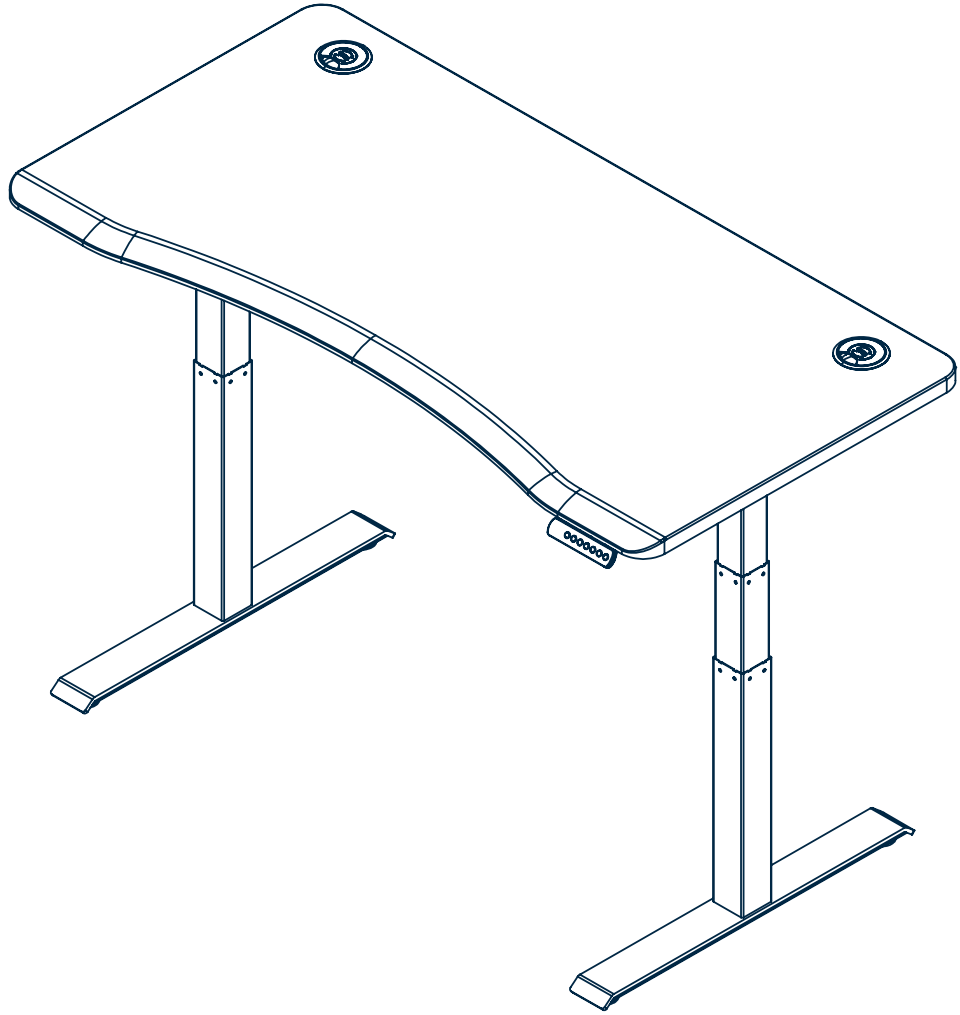

Holds up to
200 lb (90.7 kg)



2 People Required



Box 1 of 2 - Top

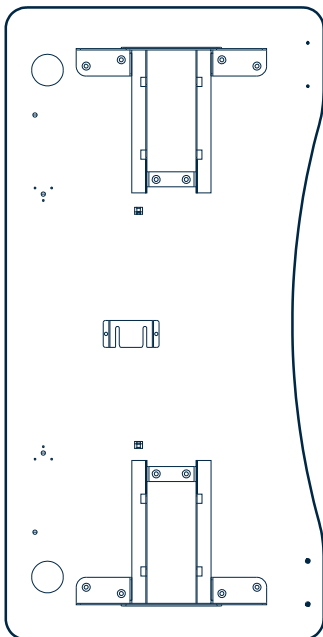

x1

Box 2 of 2 - Legs

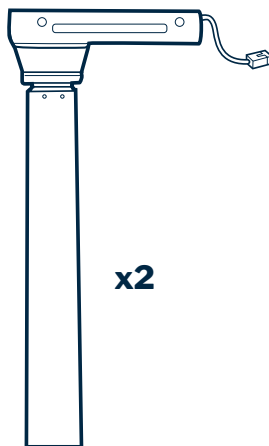

x2



x1
M10



x1
M6



x4
M10
40mm

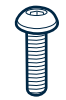

x4
M6
14mm



x2



x4
M6



x2



x1

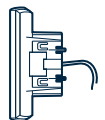

x1

*Desktop and leg kit ship in separate boxes and could arrive in separate deliveries.

Patent and trademark information: vari.com/patents | ©2022, 2023, 2024, V1.2 Varidesk, LLC All rights reserved.

Product Assembly

1

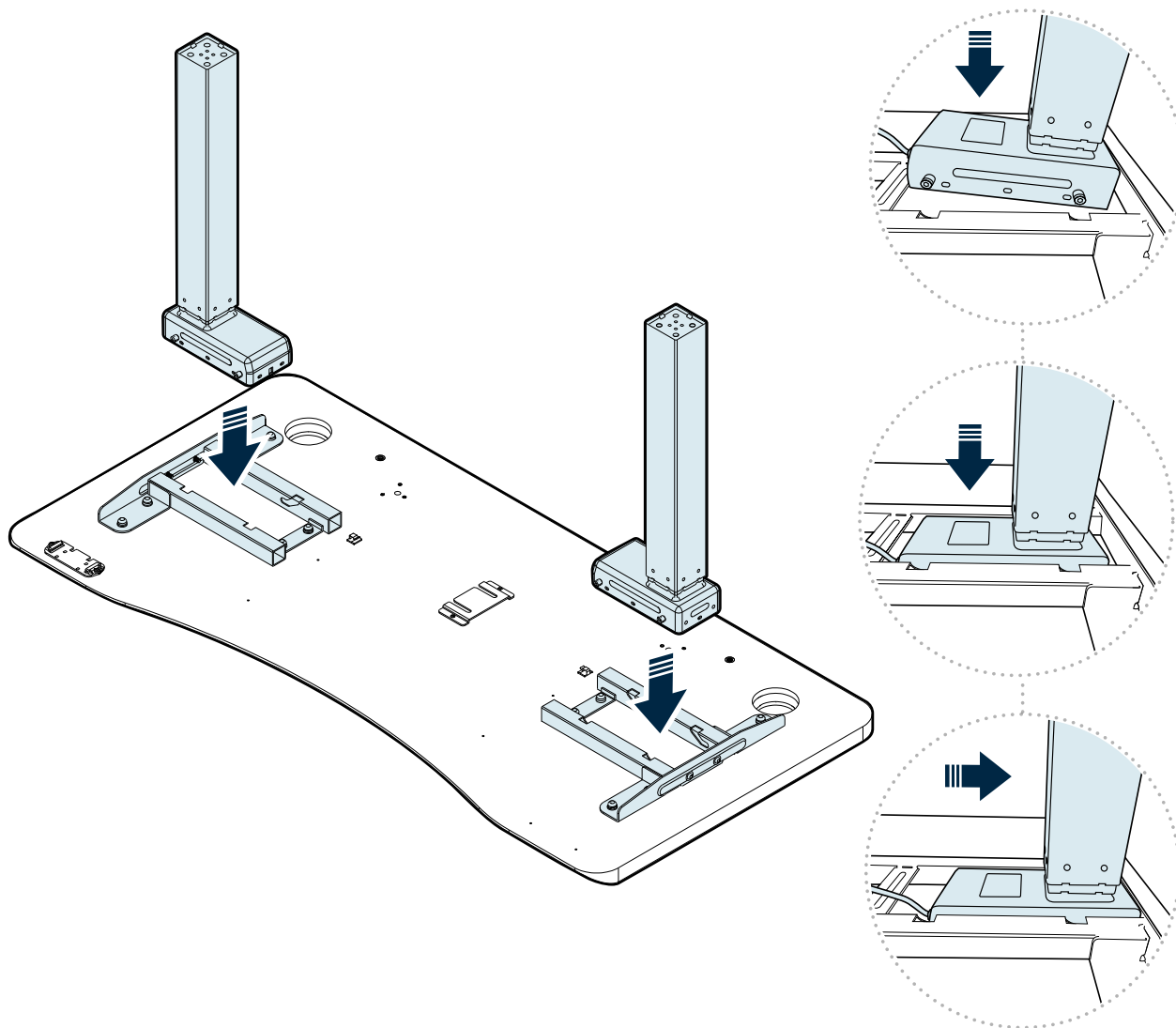

Desktop and desk legs will arrive in separate boxes. We recommend assembling the desk with the desktop face down in its box to prevent any surface scratching. Open both boxes; remove the desk legs and parts from their box.

Place the legs into the grooved areas on each side of the metal frame. (Both legs will work on the right *or* left side.) After each leg is placed into the grooved area, push the leg all the way back towards the outside of the frame, securing it in place to confirm it is properly aligned.

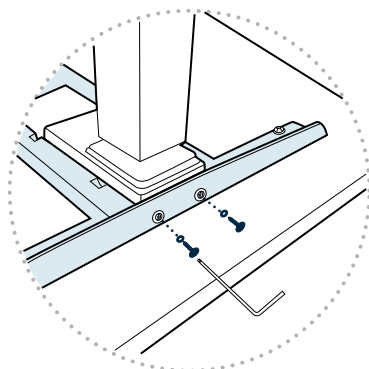

Use the smaller hex key (M6) provided to securely tighten the screws and washers (M6 - 14mm) onto each leg.

2

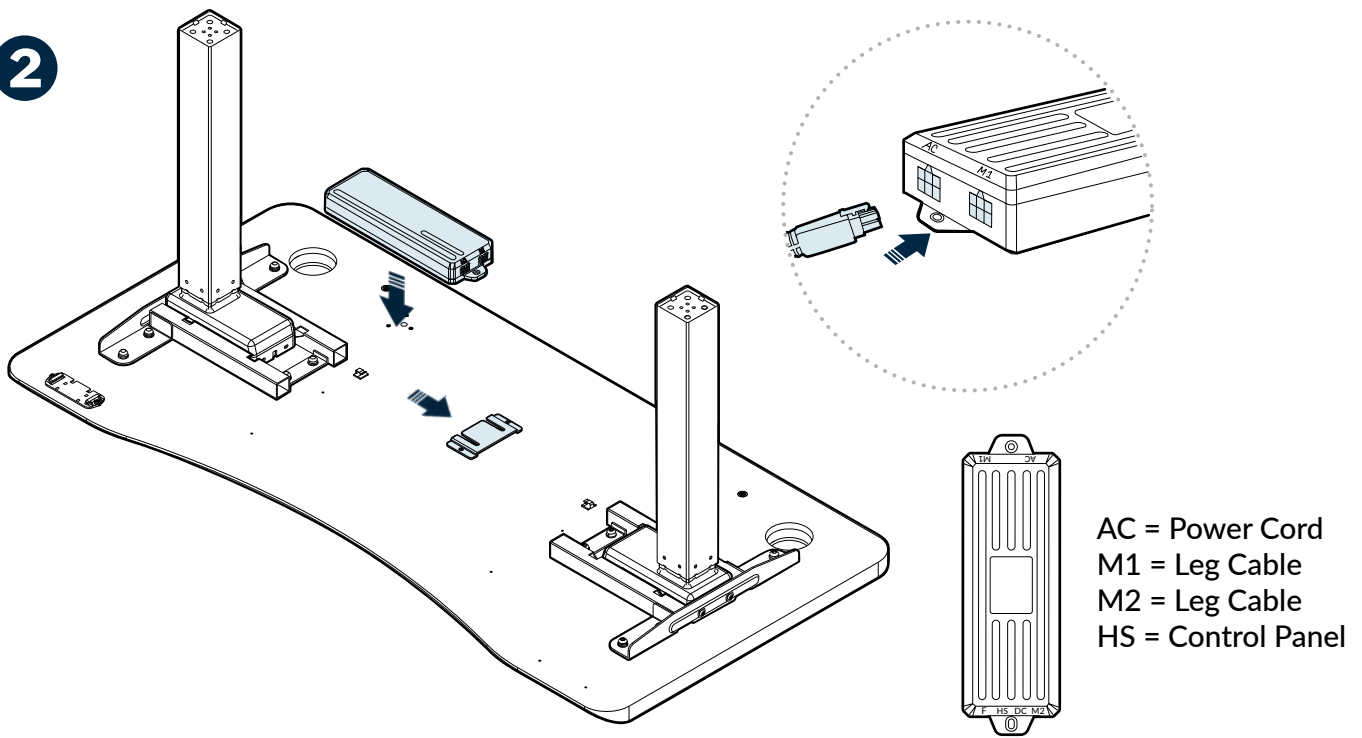

Once the legs are secured with screws and while the desk is still face down, lower the control box onto the control box bracket and slide it to engage it securely in place. When the control box is secured, connect the leg cables to the corresponding control box inputs, M1 and M2.

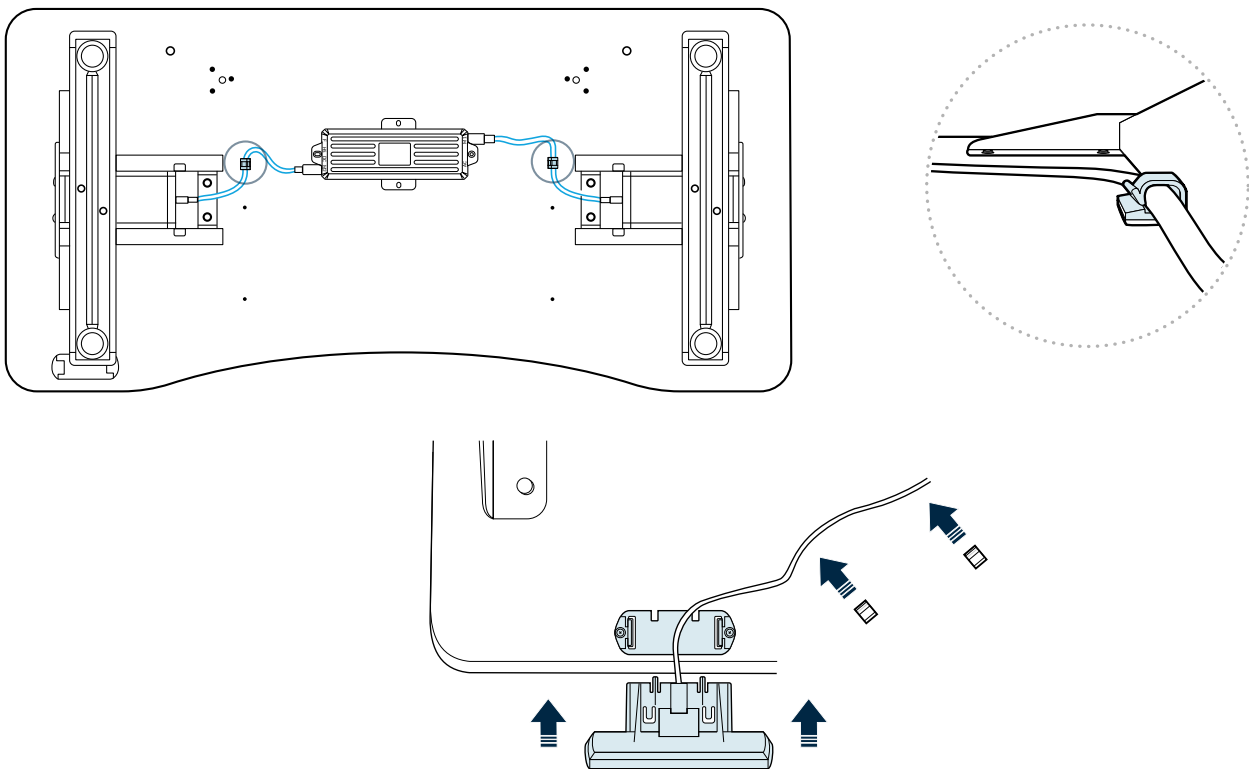

Locate the control panel and slide it into the bracket to attach. Once the panel is in place, connect its cable to the corresponding control box input, HS.

PLEASE NOTE: The control panel can be placed on the desk's right or left side, depending on the user's preference. If the bracket for the control panel is not on the preferred side, unscrew it, line it up with the pre-drilled pair of holes on the other side, and screw it in before attaching the control panel.

You can use the included adhesive clips to secure the control panel cord to the underside of the desktop to keep it out of the way. Two (2) additional adhesive clips come pre-attached to the underside of the desktop to secure and organize the leg cables.

3

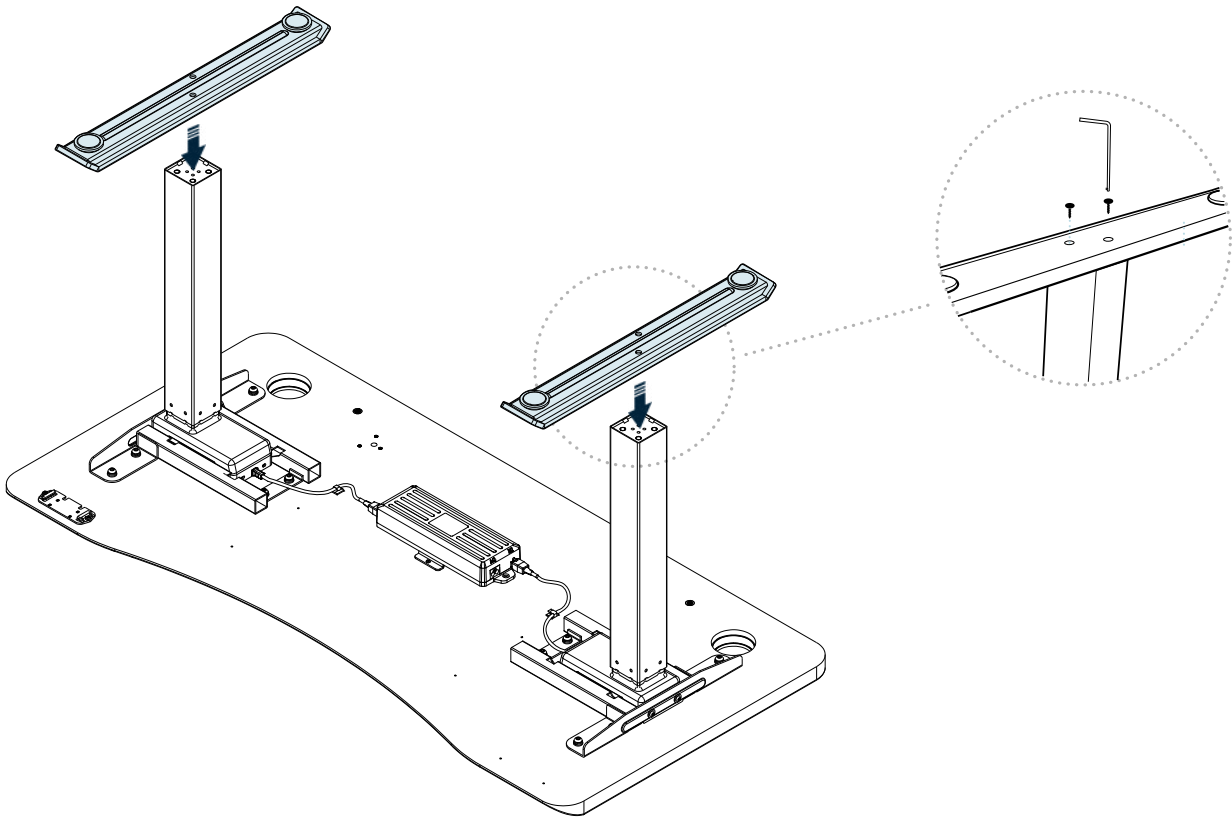

Once the control box is secure and while the desk is still face down, place one foot on top of one leg aligning the screw holes. Use the larger hex key (M10) provided to securely tighten screws (M10 - 40mm) into the feet. Repeat this step to attach the other foot.

PLEASE NOTE: A cable tray is available for purchase as an added accessory. If you plan to attach a cable tray, it will be easiest to do so while the desk is still face down.

4

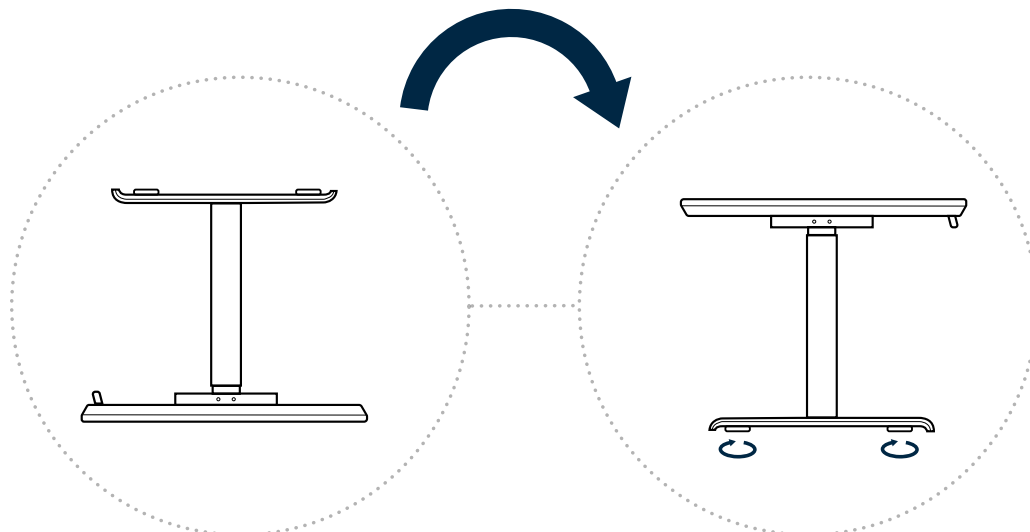

Once legs and feet are secure, two people should carefully flip the assembled desk (along the back edge to avoid damaging the control panel) to an upright position. Adjust the footpads to level the desk as needed.

Before starting your initial setup, place the desk where you want it, connect the power cord to the control box AC input, and plug the desk in.

Product Setup & Adjustments

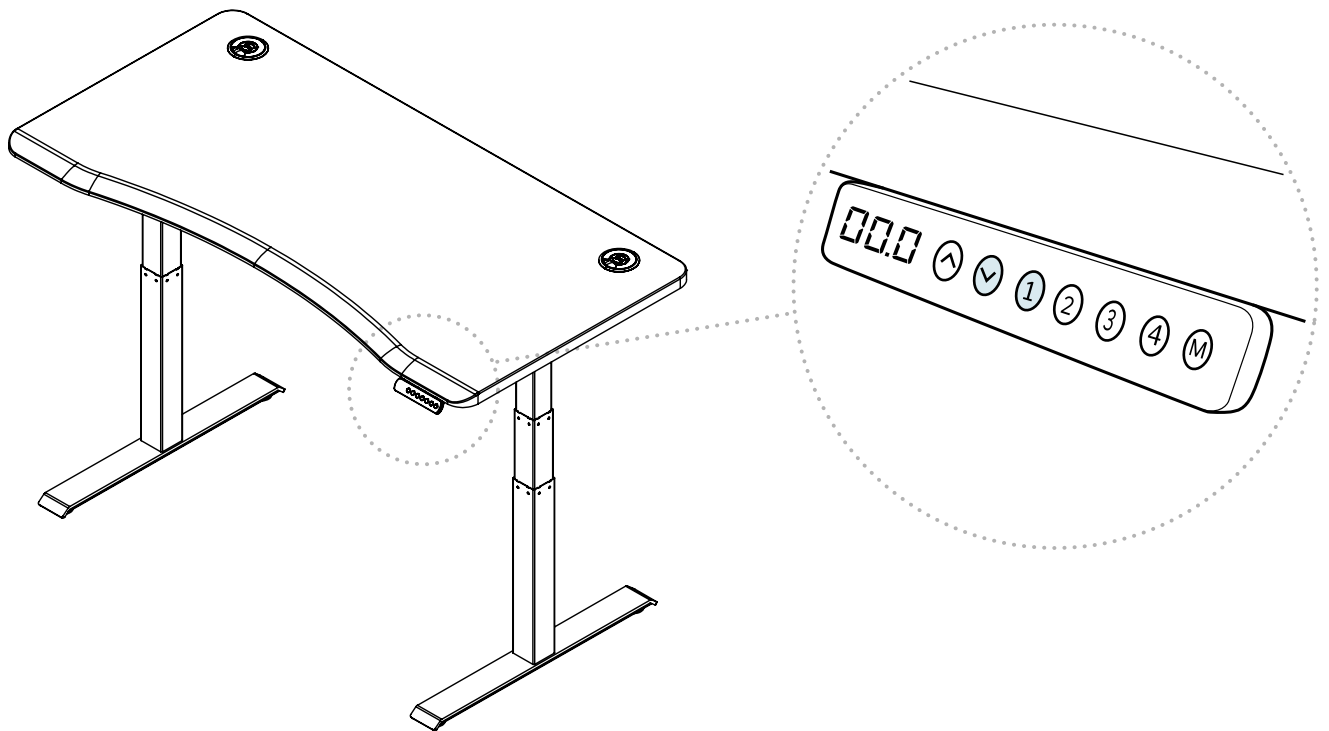

Initial Setup

Press the DOWN button on the control panel until the base reaches its lowest position. Press and hold the DOWN button again until the LED display reads “RST”.

Press and hold the 1 button (about 5 seconds) while the LED flashes “RST” and switches to either:

10.1 = One-Touch (preset buttons work with one quick press)

10.2 = Constant-Touch (preset buttons work when pressed and held down for a few seconds)

Release the 1 button. Press the 1 button again until desired setting is reached. Once the chosen setting is displayed, release the button and wait for the display to return to “RST”.

Finish the reset process by pressing and holding the DOWN button until the desk lowers a little bit more, slightly rises, and stops. Release the button. The new program is saved and your desk is now ready to use.

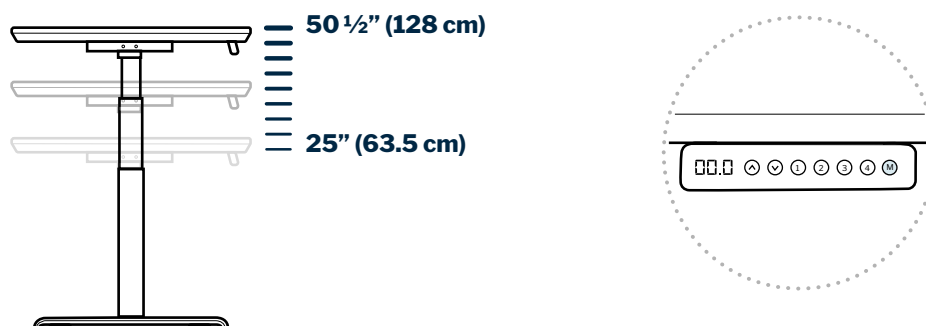

Height Settings and Preferences

The height settings range from 25-50.5 inches (63.5-128 cm). You can program 4 height preferences by raising or lowering the desk to your desired height, pressing the “M” button (you will see “S-” appear on the display), then pressing 1, 2, 3, or 4.

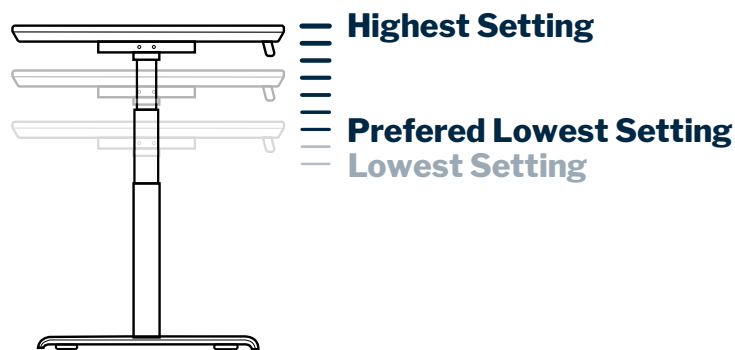

Setting Upper & Lower Limits

The height settings range from 25-50.5 inches (63.5-128 cm). If you prefer to change the settings to a more narrow range, follow the below steps.

Make sure the power is ON and a number reads on the LED display (if no number appears, please follow the Troubleshooting and Reset procedure).

To set the Upper-Limit Position: Use the UP/DOWN buttons to move the base to the desired maximum-height position. Press the “M” button and release. Press the UP button and release. The LED display will flash “S-”. Press and hold the “M” button until the LED display changes to “999”. The display will automatically return to the selected height. The new upper limit is now set.

To set the Lower-Limit Position: Use the UP/DOWN buttons to move the base to the desired minimum-height position. Press the “M” button and release. Press the DOWN button and release. The LED display will flash “S-”. Press and hold the “M” button until the LED display changes to “000”. The display will automatically return to the selected height. The new lower limit is now set.

To Remove Upper/Lower Limit Positions: Press the “M” button and release. The LED display will read “S-”. Within 5 seconds, press and hold the “M” button again for 2 seconds. The LED display will change to “555” and then automatically return to the height display. The upper and lower limits are now removed.

WARNING: A RESET procedure requires the desk base to fully retract (beyond any lower limit set). Please ensure that you have the proper clearance below the desk base.

After the upper and lower limits are set, the previous memory positions (1, 2, 3, 4) may be outside the new range of movement. If so, simply reset the memory positions.

If you attempt to revise a previously set upper or lower limit and it is outside of the existing range, you will need to remove the previously set upper/lower limits first.

Inches to Centimeters

To toggle from inches to centimeters on the display, first press the DOWN button until the desk reaches the lowest position (25”). Press and hold the DOWN button again until the display flashes “RST”. Press and hold the 2 button (about 5 seconds) until the display flashes “RST” and then switches to either **10.3** (= cm) or **10.4** (= in).

If the display is not flashing “RST”:

1. Lower the desk to the lowest position (25”), then release the button.
2. Press and hold the DOWN button until the “RST” flashes and release the button.
3. Press and hold the DOWN button again until the display shows the height of 25”, then release the button.

If the display is already flashing “RST”, begin with step 2 above.



Recalibrating

The desk may need to be recalibrated if the screen is not showing the correct height—for instance the display reads 50.5” but is in fully lowered position. To do this, press the DOWN button on the control panel until the base reaches its lowest position. Measure the distance from floor to the top surface of the desktop. If the number on the LED display does NOT match your measurement, follow these steps:

Press and hold the DOWN button until the LED display reads “RST”. Press and hold the “M” button until the LED displays the flashing height. Use the UP/DOWN buttons to change the value of the starting height so that it matches your measurement. The display will return to “RST” in about 5 seconds.

Finish the reset process by pressing and holding the DOWN button again until the desk lowers a little bit more, slightly rises, and stops. Release the button. The new starting height value is saved and your desk is now ready to use.

NOTE: The LED display has a +/- 0.1 tolerance.

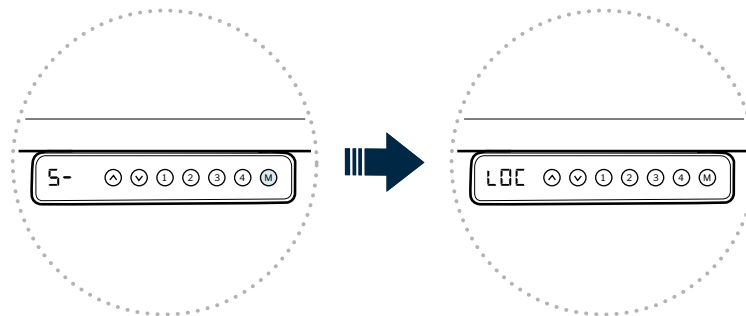

Control Panel Lock

Press and hold the “M” button (about 8 seconds) until the LED display switches to “S-” and then to “LOC”. Release the button.

Control Panel Unlock

Press and hold the “M” button (about 8 seconds) until the LED switches from “LOC” to the height display. Release the button.

Troubleshooting and Reset

If the legs have no response, your desk may need to be reset. Follow the initial setup instructions and ensure all connections are in the correct location and fully plugged in. If the legs are rising slowly, check the input power connection to make sure it’s secured correctly. If any errors continue, please contact Vari.

CODE DESCRIPTION

TROUBLESHOOTING SOLUTION

E01 E02 E03	Table Leg Failure	Disconnect the leg cables from the control box. Reconnect cables, ensuring all cables are fully connected. Remove excess weight from the desk and then follow below instructions to reset (RST) the desk. If error persists, contact Vari.
E04	Data Error	The control panel may need to be reset. Follow below instructions to reset (RST) the desk.
E05	Button Stuck	If one of the buttons on the control panel is stuck, move the affected button back and forth to release. If the button remains stuck, contact Vari.
E06	Connection Error	Check the connection between the control box and the control panel. Make sure all cables are fully connected. Follow below instructions to reset (RST) the desk.
E07 E08	Height Setting Error	E07 will display if the cable connected to the M1 port is not fully secured; E08 will display if the cable connected to the M2 port is not fully secured. Disconnect and reconnect the cable. Follow below instructions to reset (RST) the desk. If error persists, contact Vari.
H01	Motor Overuse	If the desk is raised and lowered continuously for more than 2 minutes, it will display this code and cease working temporarily to protect the mechanism from overheating. Stop adjusting the desk, and resume after 20 minutes.
RST R5F	System Reset	If the display is showing an ERROR CODE: Make sure all cables are securely connected. Press and hold the down arrow key (about 5 seconds) on the control panel until RST flashes on the screen. Release the down button, and continue with the steps below. If the display is already flashing "RST": Press and hold the down arrow key until the desk reaches the lowest height, raise slightly, and finally displaying 25.0. Do not release the key until 25.0 is shown on the control panel. The desk is now ready to use.



WARNING: Do not open any components; there is a danger of electric shock.



WARNING: Never operate this product if it has a damaged cord or plug, if it is not working properly, if it has been dropped or damaged, or dropped into water. Contact our customer service department during business hours to report any issues. Our customer service team will provide a replacement if necessary.



WARNING: Risk of electric shock. Connect this desk to a properly grounded outlet only.



WARNING: To avoid overheating, a protection program is built into the system limiting the legs from moving up and down continuously for more than 2 minutes within any 20 minute period. If the unit overheats, the display will show "Hot" or "ERR".



WARNING: Risk of finger injury—pinching hazard. Use caution when lowering desk.



CAUTION: Beverages such as water or coffee could cause product failure if spilled.



WARNING: Make sure no obstacles are in the desk's path. Make sure the desktop is not touching any walls. Make sure all cords are appropriate length to accommodate the change in height.



WARNING: To reduce risk of fire, electric shock, or personal injury, use only indoors and do not install in a wet or damp location.



CAUTION: Keep power cord away from heated surfaces and sharp edges. When the desk is not in use, store the cord underneath the desk.



WARNING: Keep plug away from heated surfaces.

- This desk is only intended to be used as described in the instructions, in commercial and household settings. Do not use attachments not recommended by the manufacturer.
- The desk edge should be at least 1" (2.5 cm) away from any surfaces or obstacles.
- This desk has no user serviceable parts.
- Unplug the desk from outlet before adding or removing any parts.

**Supplier's Declaration of Conformity
47 CFR § 2.1077 Compliance Information**

Unique Identifier: 400777, 400865, 401386, 401440

Responsible Party – U.S. Contact Information

Varidesk, LLC
450 Freeport Parkway
Coppell, TX 75019
1-800-207-2587

FCC Compliance Statement

This device complies with Part 15 of the FCC Rules. Operation is subject to the following two conditions: (1) This device may not cause harmful interference, and (2) this device must accept any interference received, including interference that may cause undesired operation.

(800) 207-2587